

How Solar Panels Work

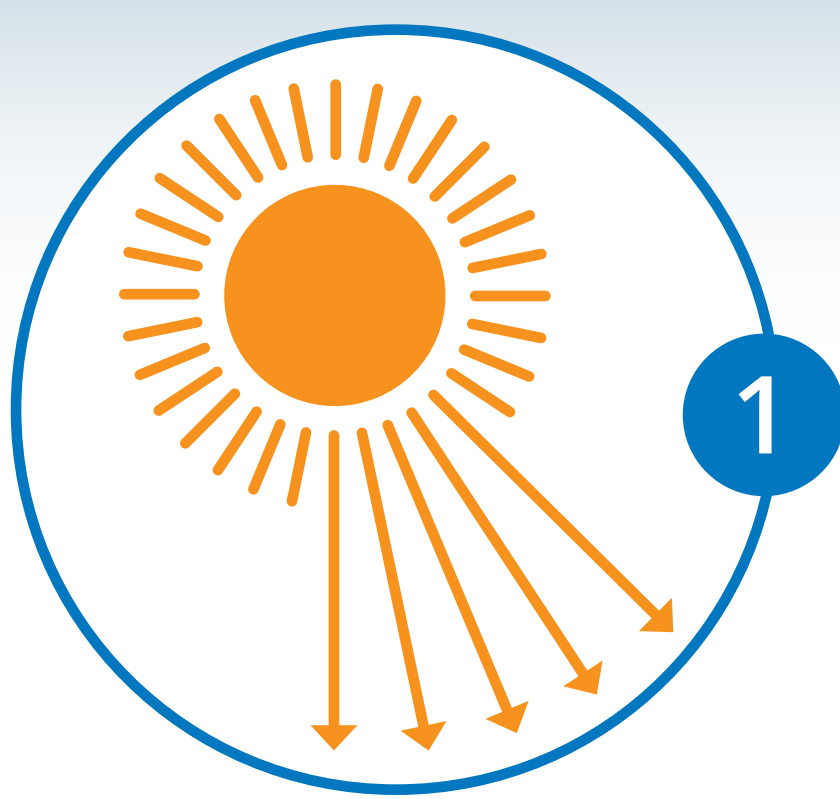

Sunlight streams millions of tiny bits of energy called photons.

When the sun's rays hit your solar panels, the semiconducting material inside absorbs the photons.

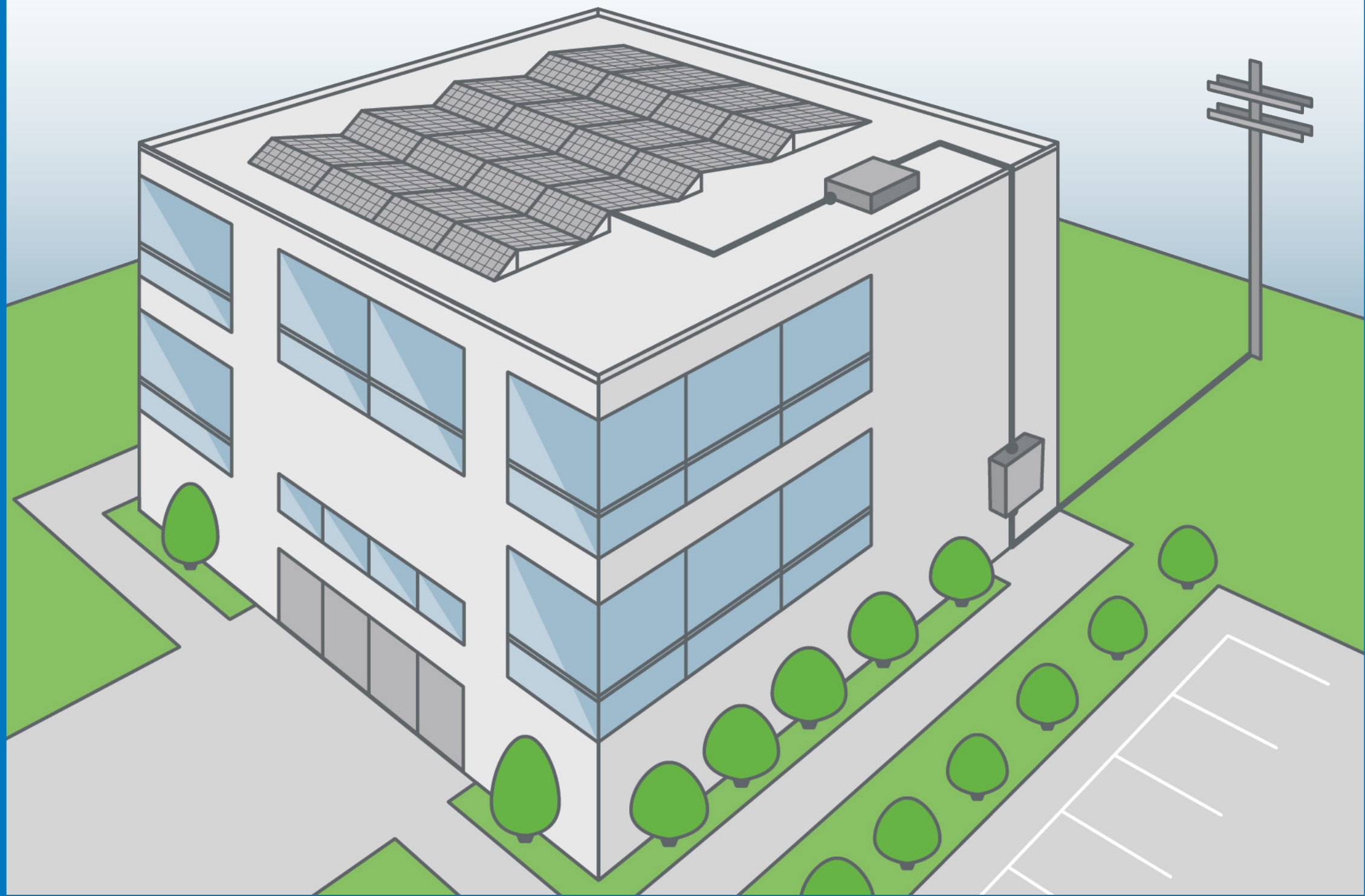
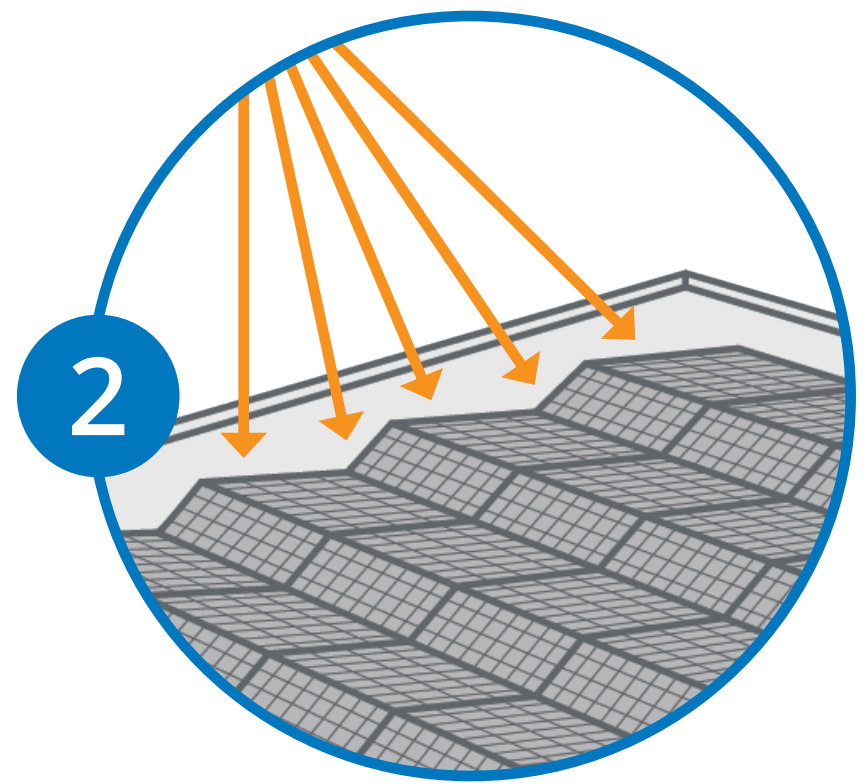

Energy from the photons forces electrons out of the panels as direct current (DC) electricity, and conductive wire carries that DC electricity to an inverter.

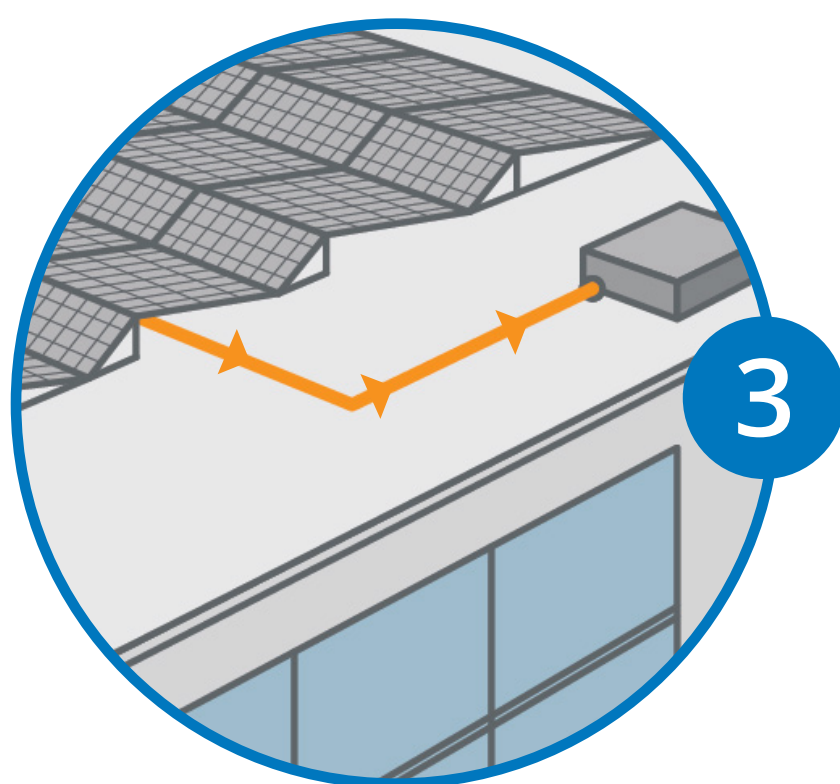

Before the power can be used, the inverter needs to transform the DC electricity to alternating current (AC) electricity.

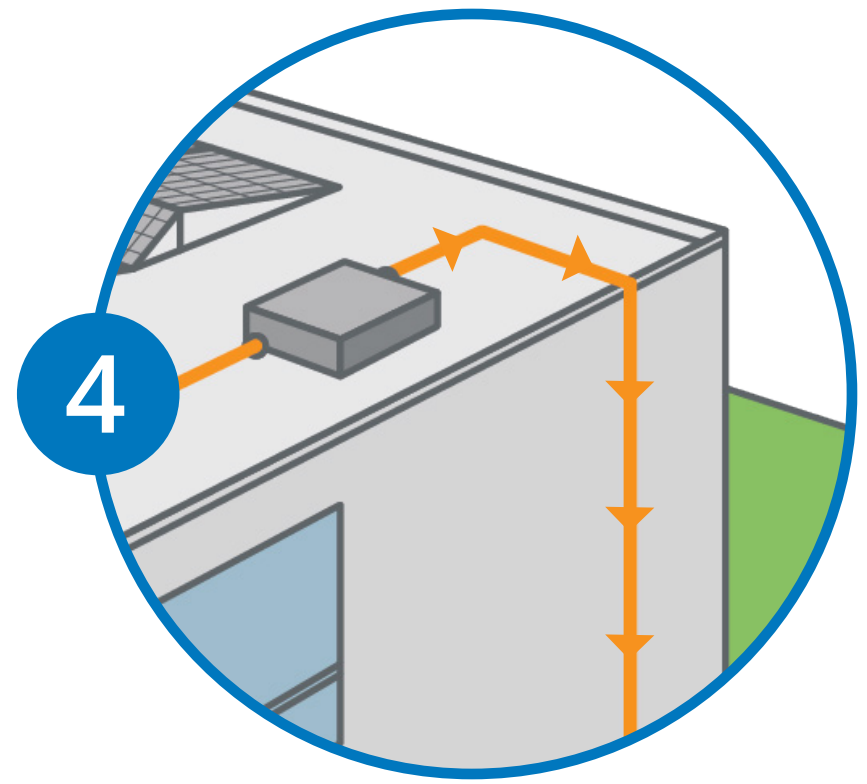

AC electricity, generated from renewable solar energy, runs from the electrical panel to all the outlets throughout your building.

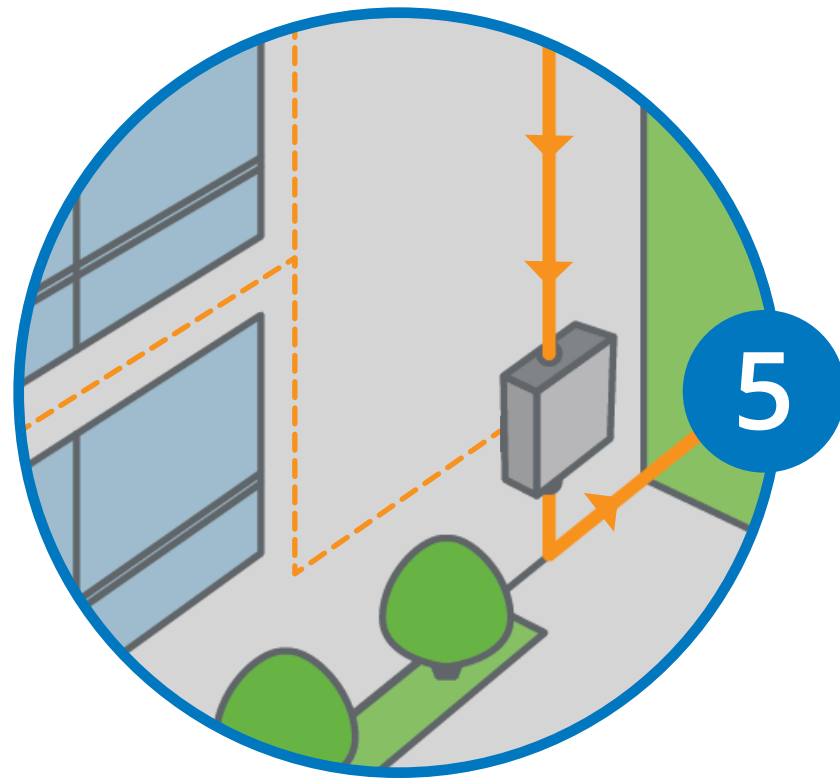

When your system produces excess electricity, it gets fed into the grid (and you can get credit).*

*Your potential solar provider can confirm whether local regulations support net metering.

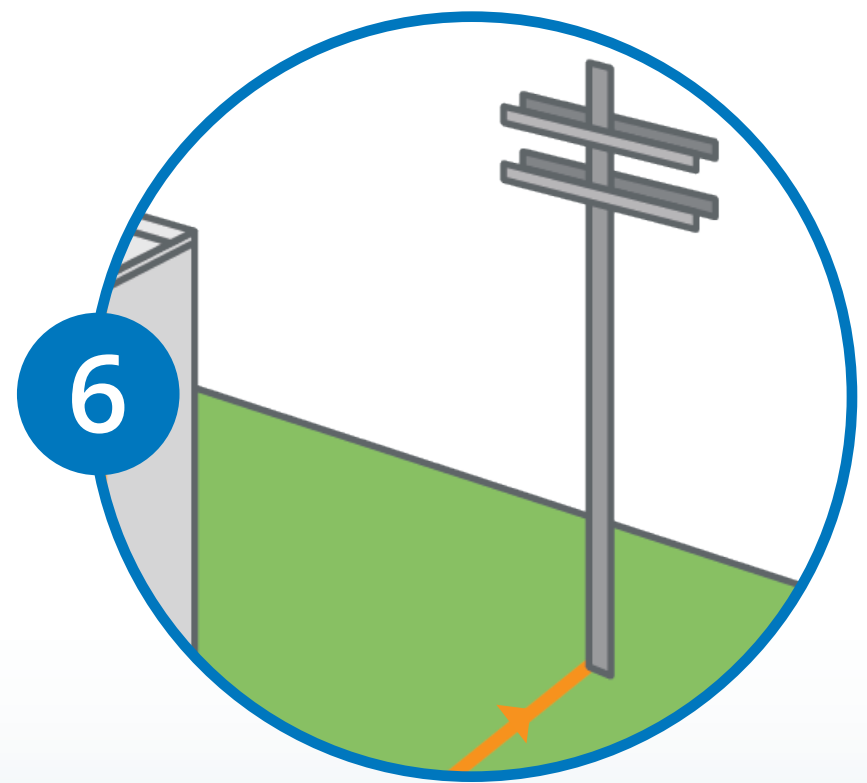

© 2016 SunPower Corporation. All Rights Reserved. The SUNPOWER logo is a trademark or registered trademark of SunPower Corporation in the U.S. and other countries as well.

For more on sustainability, renewable energy and the solar industry, visit the [SunPower Business Feed](#).

SUNPOWER®